

Injection Mold Design Guidelines

SIXTH IN A SERIES

By Dr. Paul Engelmann
and Bob Dealey
for the Mold Marketing
Task Group of the Copper
Development Association

Maximizing Performance Using Copper Alloys

Cooling With Copper Alloys

Typically the C17200, C17510 and C18000 copper alloys are used in plastic forming areas of molds because of their high thermal conductivity and unique abilities to attain a more even molding surface temperature.

The key to obtaining and maintaining plastic part dimensional stability and repeatability, critical in three and six sigma molding, is to expose each and every cavity and molding cycle to exactly the same conditions. The molding machine and/or process controls provide the ability to control melt temperatures, screw recovery, injection rates and pressures, cycle time and other parameters associated with the process. Control of both the mold surface temperature and then the range of these temperatures is a separate and frequently overlooked process.

After cavity filling, mold temperature control is the single most important factor influencing dimensional control of the molded part. All thermoplastics have to be cooled from their melt temperature to a temperature where they can be

ejected correctly without harming the part. Normally we think of the process as just cooling of the mold, but sometimes the mold is heated. Our ultimate objective is to control mold temperature within a range that yields a product within specifications at acceptable cycle times.

Placement of Coolant Channels

Ideal placement of water channels in copper alloys will enhance an already good mold temperature control material. Good design practice calls for the edge of the channels to be placed two times the diameter of the channel away from the molds plastic forming surfaces, see Illustration A. This distance has proven to be effective in providing enough support to prevent deformation of the molding surface and ideal for providing an even mold surface temperature. Closer placement to the plastic forming surface could result in greater temperature variation across the mold surface by over-cooling areas in closer proximity.

The pitch, distance between coolant channels, is also an important design consideration. The recommended distance between these channels is two to five times the diameter of the coolant channel. These recommendations have proven effective in mold applications using copper alloys. Frequently, in similar situations with molds built from tool steels, the recommendations are to place the coolant channels closer to the surface with reduced pitch distances. The superior thermal conductivity of the copper alloys allows greater freedom in channel placement.

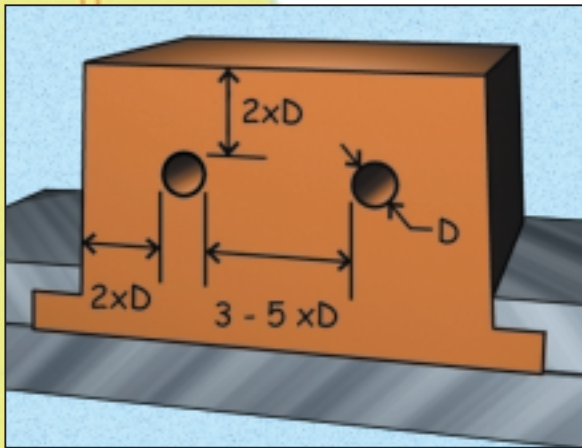

Illustration A: Water channel placement showing position between channel and edge of cavity forming alloy.

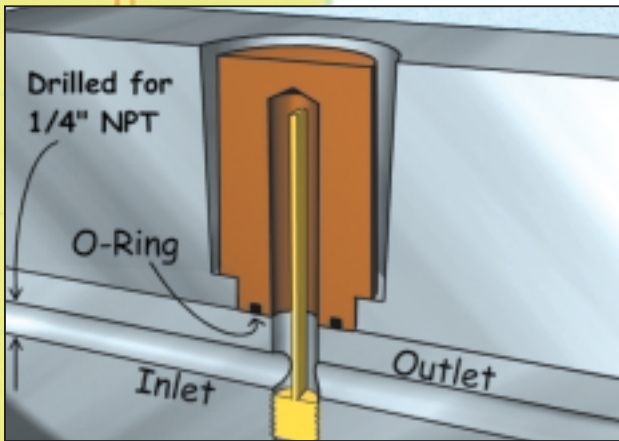

Illustration B: Baffle in series coolant circuit, positioned to force flow up and over baffle and not around.

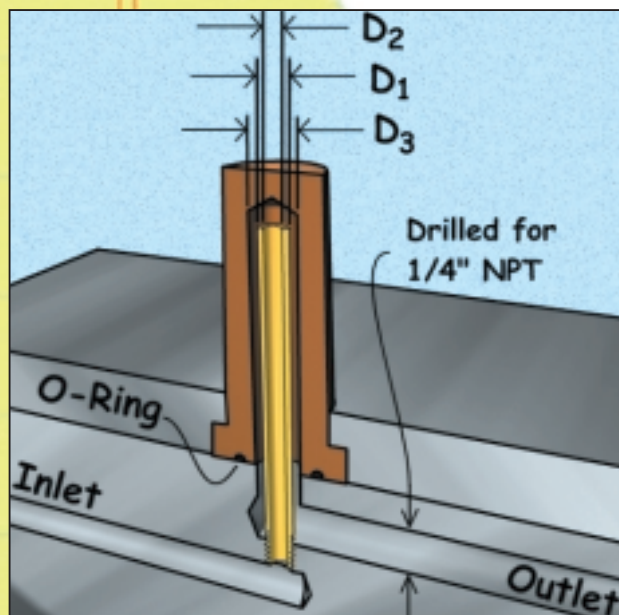

Illustration C: Bubbler in parallel coolant circuit. Area of center of tube should equal area of return.

A fluid circulating pump with capability of achieving turbulent flow rates is an important part of the equation. When using cold mold temperatures, typically below 50 degrees F, closed systems with mixtures of water and ethylene glycol are typically used. These systems require higher horsepower motors to achieve the same flow rates as water as the viscosity of the fluid changes. Temperature ranges between 50 and 210 degrees F usually use plain water. Processes over the boiling point of water generally rely on oil and usually the mold is being heated, even though the mold has to cool the plastic to eject it.

Reynolds Numbers

A method used in mold design to describe the mold temperature control fluid flow in a mold, either laminar or turbulent, is by a dimensionless number. The Reynolds number takes into account the pressure, volume and viscosity of the coolant, the resistance to flow, length and diameter of the channels and the pressure loss in the circuit. Laminar flow in a plastic mold, described by Reynolds numbers below 2,000, indicates conditions whereby

heat is not efficiently transferred from the channel wall to the circulating media. Turbulent flow, Reynolds numbers above 5,000, describe conditions where efficient transfer of heat is made from the coolant channel wall to the circulating media. Heat transfer during turbulent conditions can be as much as three to five times greater than with laminar flow. Numbers falling between 2,000 and 3,500 describe a transition phase and typically is ineffective in closely controlling mold surface temperatures.

A simplified formula for determining the Reynolds number for systems using water appears in

Injection Molding Handbook, edited by Dominick V. Rosato and Donald V. Rosato. It takes into account the fluid velocity in feet per second times the diameter of the coolant passage times a constant of 7740 divided the viscosity of water. Water viscosity changes as temperatures increase. At 32°F the viscosity of water is about 1.8 centistokes, at 100°F it has changed to about 0.7 and at 200°F about 0.3. This explains why, on occasion, increasing coolant temperature reduces part warpage and cycle time. Lessons learned in production molding have shown that with the use of copper alloys higher coolant temperatures can be used, reducing sweating of the mold and supply lines, while producing a better part at lower cycle times.

Normally mold cool programs are used to analyze effectiveness of heat transfer in the mold due to number of variables affecting the calculation. While better cooling is achieved with higher Reynolds numbers, a point of diminishing returns will be reached. When the circulating media has the capability of removing heat faster than the plastic will give it up, which is typically the case with the proper application of copper alloys, energy in cooling or heating and pumping the circulating media is wasted. Correctly designed coolant systems are important factors in obtaining fast and economical cycle time. The higher thermal conductivity of the copper alloys allows more freedom in this design over traditional tool steels.

An effective method of testing existing mold temperature control systems is to remove an exit line and measure the coolant flow through that circuit. The following table lists the flow nominal size (pipe), drilled whole diameter and the minimum water flow required insuring turbulent flow.

Pipe Size	Drilled Channel Diameter	Min. Flow (gal/min)
1/16-NT	.250	.33
1/8-NPT	.3125	.44
1/4-NPT	.4375	.55
3/8-NPT	.562	.75
1/2-NPT	.6875	1.3

Chill Plates

Earlier injection mold design guidelines describe the effective use of a chill (temperature control) plate made from the same copper alloy to insure the same thermal conductivity. Testing at Western Michigan University has proven the effectiveness of cooling multiple small cores that have small diameters preventing water passages. It is necessary that the core pin heads be firmly seated against a clean and oxidation free plate surface to insure efficient transfer of heat.

Temperature Control Channels with Baffles

Channels that divert temperature control fluids from one level to areas where heat is concentrated in the mold can use baffles, Illustration B, to positively direct the flow through the channel. This type of coolant direction is referred to as series flow when multiple baffles are used. Proper mold design starts with the diameter and area of the inlet channel. The hole for the baffle, after taking the area occupied by the baffle into account, must be twice the area of the inlet channel, to prevent flow restrictions and high-pressure losses. Remember when calculating flow channels that twice the area is not the same as twice the diameter.

Brass baffle and pressure plugs, which resists the build up of water deposits, work best in copper alloys. Most standard off the shelf baffles use a dry seal design, where standard pipe taper is 3/4 inch/foot, the dry seal design features 7/8 inch/foot taper. To prevent high hoop stresses on the copper alloys straight thread pressure plugs must be used instead of either tapered or dry seal pressure plugs.

Another important consideration is the clearance area between the tip of the baffle and the drilled hole. General design practice is to allow the same gap as the diameter of the baffle hole. Make sure that the baffle is installed at a 90° angle to the flow of the coolant to positively force the flow up and over the baffle. Otherwise leakage around the baffle will result in inefficient cooling. An effective method is to braze the baffle blade to the pressure plug and mark the outside of the plug with a line indicating the blade orientation. Check to insure that the blade is properly positioned when the pressure plug is tight.

As temperature control fluid flow is positively directed through each channel, care must be taken to

insure that the outlet temperature does not exceed the inlet temperatures by more than 3° to 5°F. High temperature differentials between individual cavities or their mold sections results in undesirable part consistency. Therefore, series circuits typically have a maximum of six to eight baffles.

Spiral baffles are useful in long slender cores as the coolant flows around the baffle, exposing the diameter of the coolant channel to more even temperatures than what could result from having up one side and down the other side of a core. Incorrect assumptions have been made that spiral baffles create turbulent flow, the fact is that spiraling water does not create turbulent flow or result in higher Reynolds numbers, by the fact that the coolant is turning.

Temperature Control Channels with Bubblers

Bubblers are also used to step coolant into areas of the mold that require heat removal. The major difference between the bubbler and the baffle is that water flows up a tube in the center of the coolant channel and cascades down the outside to the outlet, Illustration C. These cooling circuits, when more than one bubbler is used are called parallel circuits. The inlet has to have greater volume than the sum of the bubbler internal diameters to insure that each circuit will have the same flow rates.

Design of the coolant channel and the bubbler is important to successful mold temperature control. The area of the internal diameter of the bubbler tube, D2 must be exactly the same as D3 to insure that high-pressure losses are not encountered. Critical to the calculation is determining the bubbler wall thickness, D1 and the area it occupies. The coolant inlet must feed the bottom of the bubbler tube. The outlet for the coolant is around the outside diameter of the bubbler tube. Each mold coolant channel inlet and outlet must be clearly marked to insure that outside connections are correctly made, insuring the proper flow. Excessive looping can result in high-pressure losses with these cir-

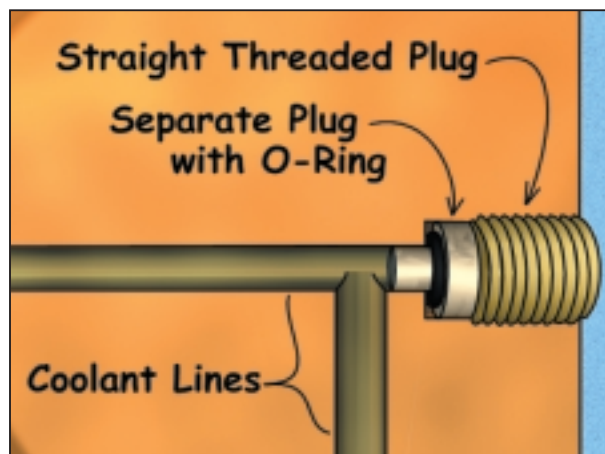

Illustration D: Recommended straight threaded pressure plug and seal.

uits and must be avoided to achieve optimum mold cooling.

Drilling and Plugging Coolant Channels

Long coolant channels are typically gun drilled in mold plates, cavities and cores. Typically, even with accurate gun drilling, the hole can wander and the tolerance of hole location is normally understood to be .0001 per inch of length. Smaller diameter drills tend to wander more than larger diameters. Care must be taken when coolant lines pass close to holes in the mold and adequate clearances must be allowed to prevent break though or leaving a weak section of the mold. With copper alloys the minimum recommended distance is approximately .100", depending upon coolant diameter, distance from drill start and the size and location of the cross hole. Coolant channels should not run parallel or in close proximity with sharp cavity corners to guard against premature failure.

The coolant channels, Illustration D, should be blocked with a fabricated straight threaded brass plug to avoid excessive hoop stresses on the copper alloys. An effective method in leak prevention is to counter bore the plug hole and then use an O-ring installed in compression. The O-ring should be replaced each time the plug is removed or at major mold maintenance cycles. Cross-drilled connecting channels should have the drill point run out in the connecting channel, avoiding stress risers.

Series and Parallel Channels

Coolant channel placement has to be considered and engineered into the mold design from the onset. Efficient mold temperature control

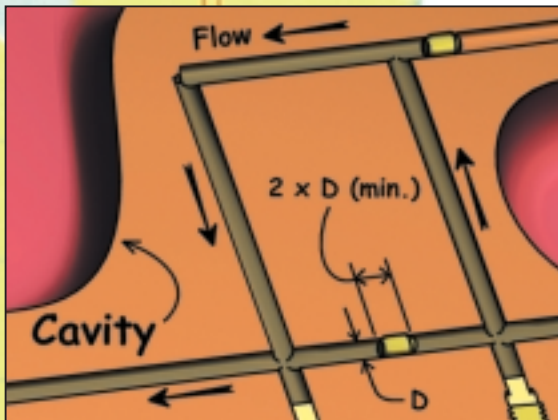

Illustration E: Looped water circuit with diverter.

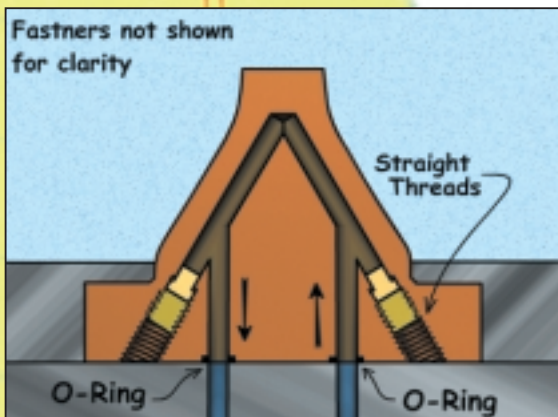

Illustration F: Intersection drilled coolant channels in hard to reach locations.

has to have the same priority in a mold design as gating and part ejection; it cannot be an afterthought. Coolant circuits can loop inside the mold with connecting channels or outside the mold with external connections.

When the mold design calls for series internal looping, and the coolant could flow in more than one direction, flow must be positively routed in the desired channel. A number of diverter plugs are commercially available to block the unused channels and direct flow through the designated route. However, a simple and recommended method is to machine a brass plug .003/.005 smaller than the coolant channel with the plug length twice the diameter, Illustration E. The plug should be inserted into the channel with a light press fit to insure it remains firmly in the correct position. The location should be measured by inserting a rod into the coolant channel and the entire circuit water tested to insure that proper routing without restriction has been achieved.

O-Rings for Sealing Coolant Channels

O-rings, when placed in compression, have proven to be the most effective method of providing a seal between two joining components in a mold. They are placed between mating components when baffles or bubblers are used. Additionally, O-rings are placed between cavity and core components when coolant is directed through the "A", "B" and support plates. The O-ring material type must have a compatible temperature rating within the range of the coolant and

mold operation temperature. On occasion a reaction can occur between copper alloys, in the presence of water and/or other fluids and certain mold steels where corrosion or pitting could take place. To prevent the possibility of this electrolytic action taking place, the copper alloy can be chromium or nickel-plated in the O-ring area. The objective is to prevent direct contact between the two materials by using a third compatible material. If the copper alloy component will have a coating or plating applied to the molding surface anyway, covering the whole component will normally suffice. A separate or different coating for the O-ring area should not be necessary.

All Water Lines are Not Straight Through Mold Components

The design and routing of coolant channels can be challenging, especially in mold cores. Straight through drilled passages are not always possible due to mold configuration, mounting and ejector pin holes and other obstacles. Machining or drilling channels that intersect and direct coolant flow to the desired location, Illustration F, should be considered. The use of innovative design methods, including baffles and bubblers, to insure proper mold temperature control is achieved pays handsome rewards in obtaining an efficient running mold. Coupling these design principles with the use of copper alloys and their superior thermal conductivity provides the best opportunity in achieving optimum molding conditions ■

Acknowledgements

The injection mold design guidelines were written by Dr. Paul Engelmann, Associate Professor, Western Michigan University and Bob Dealey, Dealey's Mold Engineering, with the support of Dr. Dale Peters, for the Mold Marketing Task Group of the Copper Development Association. Kurt Hayden, graduate research assistant, WMU, generated the illustrations. Research conducted by WMU plastic program students.

Disclaimer

These guidelines are a result of research at WMU and industry experience gained with the use of copper alloys in injection molding. While the information contained is deemed reliable, due to the wide variety of plastics materials, mold designs and possible molding applications available, no warranties are expressed or implied in the application of these guidelines.

Contact Information

Information on copper alloys is available from the Copper Development Association, at 800-232-3282. Technical clarification of the guidelines can be made by contacting Bob Dealey, Dealey's Mold Engineering at 262-245-5800

For more information about the use of copper alloys in tooling, please write in 674 on the reader service card.